

URCD-12

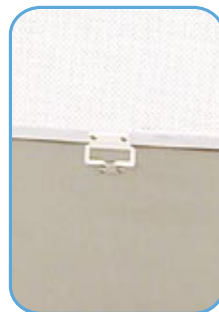

Detail : 1



Detail : 2



Detail : 3



Detail : 4

→ *Upright self-service merchandiser.*

STANDARD FEATURES

- Refrigerator system** Self-contained, bottom mounted, using environmental friendly R-134a as refrigerant.
- Controller** Multi-function microprocessor controlled with digital temperature display, humidity control.
- Temperature range** 2 °C to 5 °C
- Body and furnishing** Colorbond steel (Food grade) finish with large merchandising area to display product. Open front for self-service customers. Night curtain flowing from top to keep product at desired operating temperature. Hand operated night blind to conserve energy during night time. Sides are clear double glazed heat reflective glass to enhance product visibility. Colors can be customized to compliment store decor. Polyurethane foamed-in-place insulated bottom panels. Fluorescent light fixtures to brilliantly light the product, both from the top and from sides.
- Shelves** Colorbond steel (food grade) shelves with price tag molding. Shelves are fully adjustable and can be inclined to increase product presentation.
- Optional extra**
 - Mirror-like finish film on back panel.
 - Additional shelves.
 - Remote condensing unit.
 - Swivel caster wheels.
 - Stainless Steel body and shelves.

TECHNICAL DATA

Model number	URCD - 12	URCD - 15	URCD - 18	URCD - 20
Dimension - LxDxH (mm.)	1200 x 805 x 2020	1500 x 805 x 2020	1800 x 805 x 2020	2000 x 805 x 2020
Cooling capacity (Btu.)	6131	8496	10284	11632
Compressor (Hp.)	1-1/4	1-1/4	2	2
Shelf (Pcs.)	4	4	4	4
Display light (W)	30 x 3	36 x 1, 30 x 2	58 x 1, 30 x 2	58 x 1, 30 x 2
Power supply	220-240 v / 50 Hz / 1 Ph. (60 Hz models are available.)			

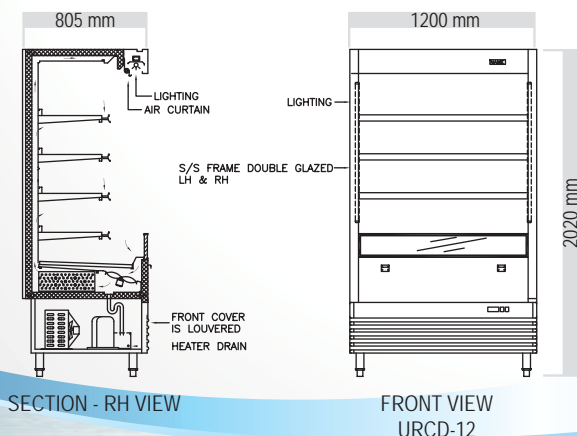

Scan me

